

2012  
**Residential  
Wiring Guide**

11th Edition



This guide is designed to help you install residential wiring safely and in accordance to the standards set by the 11th edition of the Manitoba Electrical Code 2012.

Every effort has been made to ensure the accuracy of the information in this booklet. However, in the event of a discrepancy between this booklet and the governing Manitoba Electrical Code, The Manitoba Electrical Code shall take precedence.

Remember, the Manitoba Electrical Code is constantly being updated. Be sure to familiarize yourself with the latest code requirements before you begin wiring.

The Manitoba Electrical Code has been established to protect you and your family from shock and fire hazards that may occur when wiring is improperly done, or if sub-standard materials are used.

## **Don't take shortcuts. Violating the code puts lives at risk.**

**You can view or print a copy of this guide on our website at [hydro.mb.ca](http://hydro.mb.ca).  
Hard copies are also available at your local Manitoba Hydro District Office.**

**If you have any questions or would like to make arrangements for an inspection, call 204-480-5900 in Winnipeg or 1-888-624-9376.**

Users of the Residential Wiring Guide (the "Guide") are responsible to ensure that their electrical wiring is installed in compliance with the current Manitoba Electrical Code and any other applicable laws, regulations, by-laws and codes. Users rely on the information contained in this Guide at their sole risk and are strongly encouraged to seek the advice of a qualified electrician regarding their electrical wiring installations. Manitoba Hydro shall not be liable for any injury, loss or damage caused to any person or property by reason of defects in any electrical wiring or in any improper installation of electrical wiring resulting from the use of this Guide.

# Residential Wiring Guide

## Introduction

“Do It Yourself” is a popular theme for home and cottage owners these days. Manitobans are choosing to build new homes, additions and cottages, so it is only natural that installing electrical wiring has joined the realm of do-it-yourself projects. However, electrical wiring must be installed safely and correctly in accordance with the current Manitoba Electrical Code.

Manitoba Hydro has published this guide to help you install your own wiring safely and in such a way that the finished installation will comply with the Manitoba Electrical Code. Manitoba Hydro strongly recommends that wiring be done by licensed electricians. However, if you would like to do your own wiring, and feel capable, this manual will help.

If you have any doubts about wiring a particular area of your home or cottage, do not proceed until you have confirmed the correct way to proceed.

Anyone who plans to carry out electrical installation work is required by law to obtain an electrical wiring permit. Permits for Winnipeg are issued by the City of Winnipeg Planning, Property & Development Department, Development & Inspections Division, 4th Floor, 65 Garry Street, Winnipeg R3C 4K4.

If the building to be wired is located outside Winnipeg, you may apply for a permit at any Manitoba Hydro district office, although we strongly recommend you do so at the local Manitoba Hydro office serving the district in which the premises are located.

## Manitoba Hydro service

Power is distributed to residences and cottages through overhead wires or underground cables. The service supplied is a three-wire service, which consists of two live conductors and one neutral conductor. Three wire service provides 120-volt, 120/240 volt and 240-volt capabilities.

**Chapter I – The wiring plan**

Kitchen..... 5  
Bathrooms and washrooms ..... 7  
Bedrooms ..... 7  
Laundry areas ..... 7  
Garage/Carport ..... 7  
Outdoor receptacles ..... 7  
Basement area ..... 8  
Other areas of the dwelling ..... 8  
Balcony or porch ..... 8  
Central vacuum system ..... 8  
Smoke alarms ..... 8  
Carbon monoxide alarms ..... 8  
Heat sensors in storage garages ..... 9  
Submersible pumps installed in lakes, rivers and streams ..... 9  
Service size ..... 9  
Obtaining an electrical permit ..... 9

**Chapter II – Materials**

Explanation of material and terms ..... 10

**Chapter III – Tools required**

Equipment safety ..... 14

**Chapter IV – Wiring**

Service conduit ..... 16  
Meter sockets ..... 17  
Meter sockets served from underground supply systems ..... 17  
Service box and distribution panel ..... 19  
Service grounding ..... 19

**Chapter V – Circuits**

Running cables ..... 20  
Mounting boxes ..... 22  
Receptacles ..... 22  
Colour coding of conductors ..... 25

**Chapter VI – Wiring tips**

Attaching conductors to screw type terminals ..... 26  
Use of wire connectors ..... 26  
Supporting cables ..... 26  
Metal protectors ..... 26

**Chapter VII – Inspections**

Rough-in/service inspection ..... 27  
Final inspection ..... 27  
Service inspection ..... 27

**Chapter VIII – Wiring an existing building**

Service size ..... 28  
Upgrading existing branch circuits ..... 28  
Safety ..... 29

# Chapter I - The wiring plan

In this chapter, we'll detail what information should be marked on a floor plan to develop a wiring system, the size of service required, and how to obtain an electrical permit. Figure 1 shows an example of a floor plan on which a wiring system has been developed.

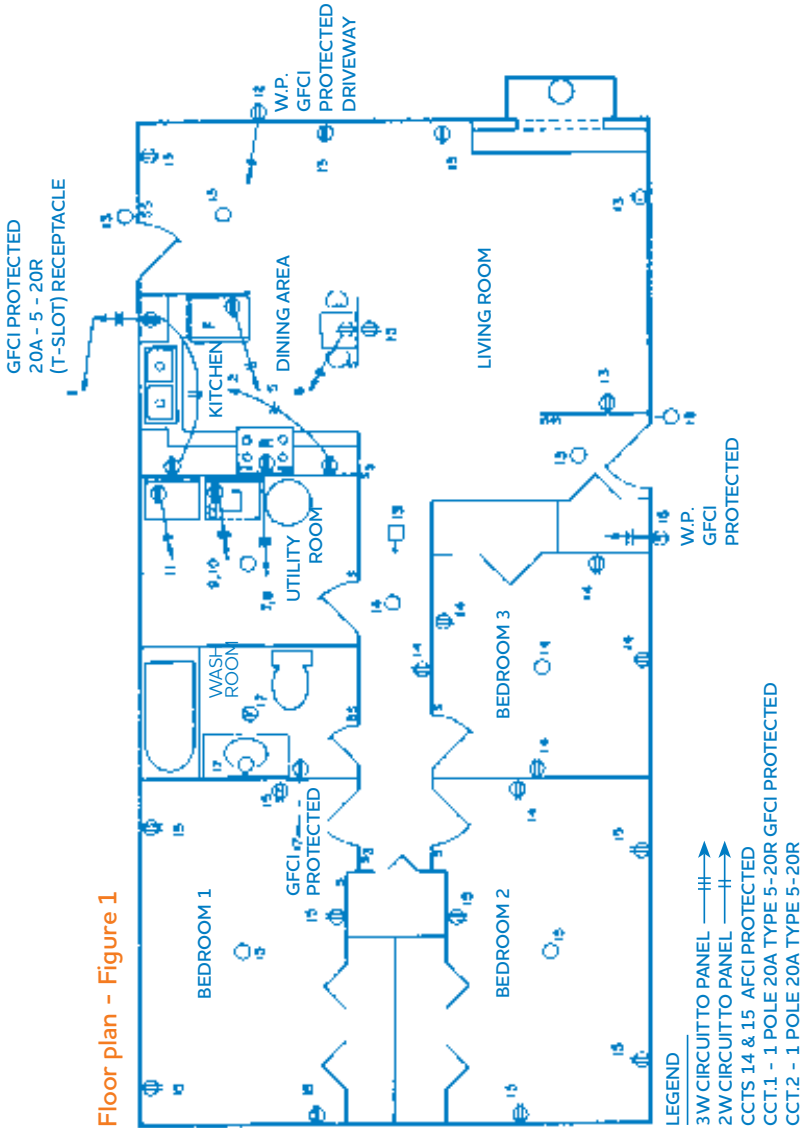

## General

- a) All 15 amp (5-15R) and 20 amp (5-20R) receptacles shall be tamper resistant and shall be marked. Receptacles that are dedicated for stationary appliances where the receptacle is inaccessible or for those located two metres above the floor or finished grade are not required to be tamper-resistant.
- b) A luminaire controlled by a wall switch shall be provided for each room.
- c) Each stairway with four or more risers must have a luminaire that is controlled by three-way wall switches located at the head and foot of the stairs. If the basement is not finished, then the luminaire is permitted to be controlled by a single switch located at the head of the stairs and provisions for three-way switching must be installed.
- d) There shall be no more than 12 outlets (lights and receptacles) on any two-wire branch circuit.

## Kitchen

In the kitchen you'll require circuits and outlets for the refrigerator, range, counter space, eating area, and lighting.

- a) **Refrigerator** – A separate receptacle, supplied from a separate circuit, for the exclusive use of the refrigerator must be installed. There is one exception to this requirement: you may connect

a recessed clock receptacle to the refrigerator circuit.

Mark the location of the refrigerator receptacle on the floor plan and indicate that the circuit goes directly to the distribution panel.

- b) **Range** – A separate receptacle must be located in approximately the centre of the wall space where the range is located (130 mm maximum from the floor and oriented as shown in Figure 2 on page 6).

Mark the location of the receptacle on the floor plan and indicate that the circuit goes directly to the distribution panel.

Where a gas (natural gas or propane) piping system or a natural gas connection outlet has been provided for a free-standing, all natural gas range, one receptacle must be located behind the intended natural gas range location, not more than 130 mm from the floor and as mid-point as possible.

- c) **Dining area forming part of a kitchen** – You must install at least one receptacle in a dining area that forms part of a kitchen. Receptacles in this area must be supplied from a branch circuit that does not supply any other outlets.

Mark the location of the outlet on the floorplan and indicate that the circuit goes directly to the distribution panel.

**d) Usable counter space –**

At least two receptacles (15 A - CSA configuration 5-15R, or 20 A - CSA configuration 5-20R) shall be provided for kitchen counters. These receptacles must be installed so that no usable counter space, as measured along the wall line, is farther than 900 mm from a receptacle (excluding the area directly behind the kitchen sink). If you are installing a peninsula or a fixed island in your kitchen you will have to install a receptacle for either or both of these areas if they have a continuous dimension greater than 300 x 600 mm. Receptacles located within 1.5 metres of the sink must be protected with a ground fault circuit interrupter (GFCI) of the Class A type. This will require that they be of the 20 A, 5-20R type, connected to a 20 A circuit breaker or fuse and wired with No.12 AWG copper wire.

If more than two receptacles are required, they can be installed as either a three-wire 15 A circuit or two-wire 20 A circuit. This three-wire split receptacle circuit

consists of a duplex receptacle wired in such a manner to provide 15 A of power from each outlet. No more than two receptacles, of either type, shall be permitted to be connected to any one circuit.

Mark the location of the receptacles and their circuitry on the floor plan. Indicate the two-wire or three-wire circuits going directly to the distribution panel.

**e) Built-in microwave oven –**

If you plan to install a built-in microwave in an enclosure, a receptacle supplied from a separate circuit must be installed. This circuit must not be considered as forming part of other kitchen circuits. On the floor plan, mark the location of the receptacle and its circuit, and indicate that the circuit goes directly to the panel.

**Range receptacle installation - Figure 2**

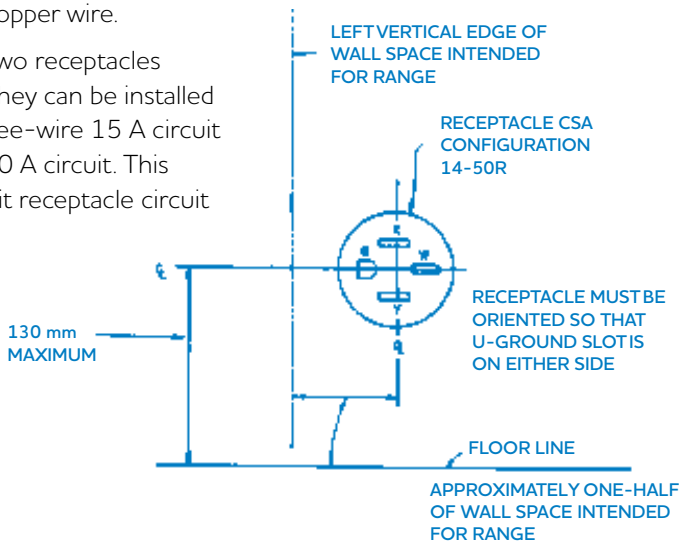



#### **f) Cord-connected range hood or combination microwave oven/range hood unit**

The receptacle required for this appliance is allowed to be installed in a cupboard or cabinet.

#### **g) Additional outlets**

Outlets for general lighting, task lighting, and exhaust fans should be marked on the wiring plan.

Their circuitry can be connected with the general circuitry in the structure.

#### **Bathrooms and washrooms**

A receptacle must be installed at each hand wash basin, and the receptacle must be protected by a GFCI. Mark the locations of all the bathroom outlets (lights, fans, and hand basin receptacles) on the floor plan.

#### **Bedrooms**

Branch circuits which supply receptacles installed in the sleeping facilities of a dwelling unit, must be protected by an arc-fault circuit interrupter (AFCI). AFCI is a device intended to provide protection from the effects of arc-faults by recognizing characteristics unique to arcing and functioning to de-energize the circuit when an arc-fault is detected.

#### **Laundry areas**

If you plan to include a laundry area in your home, you will require a receptacle served by a separate two-wire circuit for a washing machine and a separate receptacle supplied from a separate three-wire circuit for an

electric dryer or in the case of a natural gas dryer, a separate, two-wire circuit.

Mark the location of the receptacles on the floor plan and indicate the circuits going directly to the distribution panel.

#### **Garage/Carport**

At least one duplex receptacle is required for each car space in a garage or carport. Additional receptacles are required within one metre of each cord-connected garage door opener in the garage.

A dedicated circuit is required for these receptacles except the lights for the garage and door operator may be connected to this circuit.

Mark the location of the receptacles on the floor plan and indicate that the circuit goes directly to the distribution panel.

#### **Outdoor receptacles**

You must have at least one receptacle installed for the driveway area along with an additional outlet accessible from grade level on the outside wall of a cottage or home for use with appliances designed to be used outdoors. Each of these receptacles is required to be connected to its own separate branch circuit.

All outdoor receptacles located within 2.5 metres of ground or grade level must be protected by a GFCI.

Mark the location of each receptacle on the floor plan and indicate that the circuit goes directly to the distribution panel.

## Basement area

Even if you do not plan to finish your basement at this time you must install at least one receptacle in the basement area. This receptacle may be on a circuit that supplies other general use receptacles.

## Other areas of the dwelling

General use receptacles in bedrooms, living rooms, and other areas must be located so that no usable wall space is farther than 1800 mm from a receptacle. The wall space that is to be measured for the location of the receptacles should not include:

- Doorways
- Areas occupied by a fully opened door
- Windows that extend to the floor
- Fireplaces
- Other permanent installations that limit the use of the wall space.

No point in a hallway of a home or cottage is to be farther than 4.5 metres from a receptacle, without going through a doorway. For example, an outlet in a bedroom cannot be counted as a hallway receptacle.

All general use outlets must be shown on the plan and the circuitry should be marked to indicate that no more than 12 outlets are connected to one two-wire circuit.

## Balcony or porch

In an area such as a balcony or porch, you must install at least one receptacle.

## Central vacuum system

If you plan to install a central vacuum system, it must be supplied by a receptacle on a separate circuit.

## Smoke alarms

Smoke alarms with battery backup must be installed on all floors, including basements. If the home is a split-level or a bi-level and it is 900 mm (3 feet) above or below the adjacent level, it must be counted as a different floor and must have its own alarm. A smoke alarm with battery backup must be installed in each bedroom and there must be one in the hallway that serves the bedroom(s).

They must operate at 120 volts and be supplied by an unswitched lighting branch circuit or a combination lighting and receptacle branch circuit, that is not protected by a GFCI or an AFCI.

Smoke alarms shall be interconnected so that the operation of any one device will activate all the other alarms. Combination smoke and carbon monoxide alarms may be used as they can reduce the number of units to be maintained.

**NOTE:** *Smoke alarms must be installed according to the manufacturer's instructions.*

## Carbon monoxide alarms

A carbon monoxide alarm is required in every home that contains a fuel-burning appliance or an attached garage. Alarms are to be installed either inside each bedroom or, if

outside, within 5 metres of each bedroom door.

They must operate at 120 volts and be supplied by an unswitched lighting branch circuit or a combination lighting and receptacle branch circuit.

Carbon monoxide alarms shall be interconnected so that the operation of any one device will activate all the other alarms. Combination smoke and carbon monoxide alarms may be used as they can reduce the number of units to be maintained.

**NOTE:** *Carbon monoxide alarms are to be installed according to the manufacturer's instructions.*

### Heat sensors in storage garages

A fixed temperature heat sensor shall be installed in an attached garage and is to be installed on the ceiling of the garage or bottom of a ceiling joist of garages with no ceiling. Permanent wiring to an electrical circuit must ensure that activation of the sensor will cause all alarms within the dwelling to sound.

### Submersible pumps installed in lakes, rivers and streams

If you plan to install a submersible pump in a lake, river or stream, the voltage supplying the pump must not exceed 150 volts to ground and the branch circuit that supplies the submersible pump must be provided with GFI protection with a high enough setting to allow normal operation of the pump, but must limit the ground fault current to less than 10 mA for a period not exceeding 2.7 seconds.

Only heat trace cable having a metal braid or sheath is allowed to be installed on water lines to prevent freezing. This metal braid or sheath must be bonded to ground.

The heat trace circuit must be protected by a GFI with a high enough setting to allow the normal operation of the heater. The setting for this GFI is from 25 mA to 30 mA. The GFI required for both of these types of installations is different from the normal GFCl for your bathroom or outside receptacles, which has a setting of between 4 mA to 6 mA.

### Service size

Manitoba Hydro recommends a minimum service size of 100 amps, complete with a 24-circuit distribution panel. A 100-amp service should be capable of supplying up to 10 kW of electric heating, in addition to the normal loads in a residence or summer cottage.

If you are installing more than 10 kW of electric heating, a service larger than 100 amps is required. The service size should be based on calculated kilowatt demand, which takes into consideration the floor area, appliances, electric heating, pumps, motors, and other loads that may be installed, such as hot tubs and saunas.

### Obtaining an electrical permit

As mentioned in the introduction, you must obtain an electrical permit before starting any wiring.

You must apply for an electrical permit in person. Bring your floor plan (see page 4), service size, service equipment drawing and a list

of materials to be used (note quantity and types). (A list of materials can be obtained from the wiring plan).

If your floor plan and supporting information is acceptable to Manitoba Hydro's electrical inspectors, you will be issued a permit upon payment of

the appropriate fees. The fees are assessed in accordance with the current Manitoba Hydro schedule of electrical permit fees.

If you plan to build a new structure you must contact your local Manitoba Hydro district office to determine where the electrical service will be attached to the building. (See "Service conduit" Chapter IV.)

## CHAPTER II – MATERIALS

As mentioned in the previous chapter, you should take a list of materials needed for your wiring installation when you apply for the permit.

The Manitoba Electrical Code requires that all wiring materials be approved by an accredited certification organization such as those below. Failure to use approved materials will result in the inspector refusing to accept the installation. Manitoba Hydro will not connect the service until the inspector accepts the installation.

Electrical inspection authorities across Canada will accept electrical equipment with certification markings, other than the CSA logo. Here are some logos that denote approved electrical and gas equipment:



**1) Canadian Standards Association**



**2) Underwriters Laboratories Inc.**

(The UL logo without the small "c" is not acceptable for use in Manitoba.)



**3) Warnock Hersey**



**4) Electrical Testing Laboratory**

(The ETL logo without the small "c" is not acceptable for use in Manitoba.)



**5) Canadian Gas Association**



**6) Underwriters Laboratories Canada Inc.**

For further information, contact your local electrical inspection authority or the Office of the Fire Commissioner, Inspection and Technical Services Manitoba.

## Explanation of materials and terms

### American Wire Gauge Number (AWG):

The standard measurement for the diameter of a wire is the American Wire Gauge (AWG) number. It is a measurement of the wire only, and does not include the insulation covering the wire.

### Single conductors:

Single conductors must be covered by insulation, except when the conductor is for a service neutral or for grounding purposes, in which case it may be bare. Single conductor cables are normally installed in service raceways.

### Multi-conductor cables:

Multi-conductor cables are cables consisting of two or more conductors. There are two types of non-metallic sheath (NM) cable commonly used for wiring a home or cottage. The first is NMD90, which is used indoors for the bulk of your circuit wiring. The second is NMWU, which is used outdoors and may be buried in the ground. NM cable is identified by the size and number of conductors it contains. For example, a cable with two #14 AWG conductors (one white and one black), and a bare bonding conductor, is called "14/2 with bond."

### Common wire sizes:

There are four basic wire sizes that are commonly used for wiring the circuits of a home or cottage: #14, #12, #10, and #8 AWG.

- # 14 AWG is used for 15 amp circuits that supply loads like receptacles, switches, and lights.
- # 12 AWG is used for 20 amp circuits that supply loads like 3,000 watt hot water tanks.
- # 10 AWG is used for 30 amp circuits that supply loads like electric clothes dryers.
- # 8 AWG is used for 40 amp circuits that supply loads like an electric range.

The size of the conductor for each circuit is determined by the amperage required for the particular circuit.

The following are some other common copper conductor sizes which are used in the service entrance:

- #3 AWG with insulation on the conductors is used with a 100 amp service.
- #3/0 AWG with insulation on the conductors is used with a 200 amp service.
- #6 AWG bare is used as the grounding conductor on 100 and 200 amp services.
- #6 AWG bare is used as the neutral conductor on 100 amp services.
- #3 AWG bare is used as the neutral conductor on 200 amp services based on 3/0 conductor.

## Electrical boxes:

The most commonly used electrical boxes for residential and cottage wiring projects are octagonal, square, and device types. There are various sizes of boxes. The size you use depends on the number and size of conductors, number of wire connectors used, and whether or not a device such as a receptacle or switch will be mounted in the box. When cables are installed in electrical boxes, care must be taken to ensure the proper size of box is used.

The most common size of octagonal box used for residential wiring is 4 x 1.5 inches. You may install 10 - #14 AWG insulated conductors or 8 - #12 AWG insulated conductors in this size of box. If you need to install more conductors then use a deeper box or employ an extension ring. The two most common sizes of device boxes are 3 x 2 x 2.5 inches and 3 x 2 x 3 inches. Where switches or receptacles are to be installed in these boxes, the following maximum number of insulated conductors may be installed:

### 3 x 2 x 2.5 inches

- 5 - #14 AWG insulated conductors, or
- 4 - #12 AWG insulated conductors

### 3 x 2 x 3 inches

- 7 - #14 AWG insulated conductors, or
- 5 - #12 AWG insulated conductors

A 4 11/16 inch square box is required for dryer and range receptacles

Figure 3 illustrates the various types of boxes most commonly used in residential and cottage wiring.

## Electrical boxes - Figure 3



REMOVE ONE SIDE FROM EACH BOX



GANG SECTIONAL BOXES  
TOGETHER TO FORM  
LARGER BOXES



OCTAGONAL OUTLET  
OR JUNCTION BOX



BLANK COVER



LAMP HOLDER COVER



SQUARE JUNCTION BOX AND COVER

## Switches:

There are four common types of switches: single-pole, three-way, four-way, and dimmer.

- A single-pole switch controls a light or receptacle from one location only.
- A three-way switch has three terminals and operates in conjunction with another three-way switch to control a receptacle or light from two locations.
- A four-way switch has four terminals and is used in conjunction with two three-way switches to control a light or receptacle from more than two locations.
- A dimmer switch allows you to turn an incandescent light on or off, and vary the brightness of the light according to your needs.

Figure 4 illustrates the different types of switches.

## Receptacles:

There are several grades of receptacles available. Receptacles in areas such as the kitchen or driveway and those used for heavy loads, should be of top quality, as they will be used constantly.

Typical schematic diagrams - Figure 4

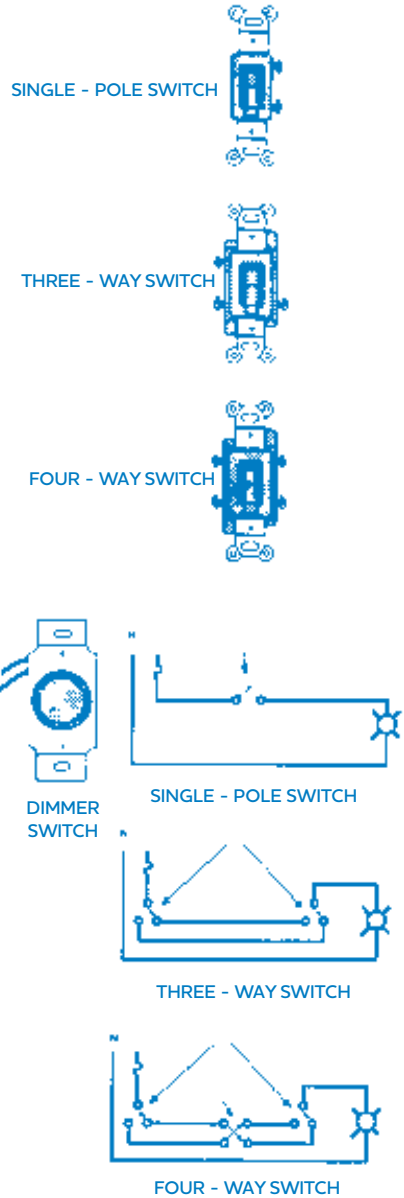

## CHAPTER III – TOOLS REQUIRED

The following are some of the tools required to install electric wiring. (You may already have many of them).

### • Screwdrivers:

- #8 Robertson
- #6 Robertson
- Standard Flat blade

### • Pliers:

- lineman's pliers
- multi-purpose diagonal cutters
- needle nose

### • Miscellaneous:

- Allen key
- cable stripper
- hammer
- knife
- power drill
- voltage tester
- wood drill bits

## Equipment safety

1. Always keep your power tools cleaned and lubricated, according to the manufacturer's instructions in the operating manual.
2. Check power cords and extension cords frequently. If the insulation is broken or the power cord is frayed, replace it immediately. Do not try to fix it.
3. Always disconnect equipment by removing the plug from the electrical outlet first. Then disconnect the cord from the power tool.
4. Never operate power equipment while standing on wet ground or in water.
5. When you have finished using your power tools, store them in a clean, dry place. Don't leave them lying around unprotected.
6. Be careful with extension cords. Run them along walls if possible, so that no one will step on them or trip over them. Never set a heavy object on an extension cord.



## CHAPTER IV – WIRING

Once you have gathered the required tools and materials, and obtained your electrical permit, you will need to arrange for electricity at your construction site. You may wish to have power at your construction site to operate your power tools. There are several ways to do this:

- Install a temporary builder's electrical service on the site. For a non-refundable installation fee, Manitoba Hydro will connect it.
- Borrow power from a neighbour, using a three-wire outdoor cord of a sufficient size to prevent excessive voltage drop due to the length of the cord.
- Install your permanent building service and one convenience outlet in your home or cottage. For an additional inspection fee, Manitoba Hydro will connect the service prior to the installation of rough-in wiring.

Service includes a service entrance head, service conduit, mast (if required), meter socket, main service box, distribution panel and a grounding electrode.

## Service conduit

Before you install the service entrance equipment on the building, contact your local Manitoba Hydro district office to find out where the service will be attached to the building.

It's also your responsibility to clear brush and trees which are between your building and the hydro pole.

The service conduit protects the service conductors between the service entrance head and the main service box. These are the conductors that Manitoba Hydro will connect to on the outside of your building. The size of the service conductors depends on the size of service required.

If the structure is tall enough, the service entrance head and conduit can be mounted on the wall, without the use of a service mast (see Figure 5).

If the building is so low that proper clearances cannot be met with the service entrance head mounted on the wall, a service mast kit will have to be installed (see Figure 6).

The following are some of the measurements which must be observed (see Figure 7):

- When the Hydro service conductors run to your building across a finished grade or landscaped yard, a minimum clearance of 3.5 metres is required.
- When the Hydro service conductors run to your building across a driveway, a minimum clearance of 4 metres is required.
- When the Hydro service conductors run to your building across highways, streets, and alleys, a minimum clearance of 5.5 metres is required.



## Meter sockets

The meter socket must be installed at a distance of not less than 1200 mm and not more than 1800 mm from the finished grade or deck. The type of meter socket to be installed generally depends on the location of the service box.

If the service box is located above grade, as shown in Figure 8, you should use a double hubbed meter socket. However, if the service box is located below grade, such as in the basement, you should use a single hubbed meter socket as shown in Figure 9. In either situation, the two live service conductors, which are usually black, are connected to the line side terminals of the meter socket. The service neutral conductor (bare or white) is connected to a neutral lug in the meter socket. In most cases, the service neutral conductor is not cut, but laid into the neutral lug and then run to the service neutral block in the service box. The service raceway entering a building must be sealed and suitably drained where it enters the building above grade level.

## Served from underground supply

Meter sockets served from underground supply systems by Manitoba Hydro must be designed for connection to an underground supply system. They shall be equipped with approved studs on the line side to provide for the connection of compression-type wire connectors.

A minimum 63 mm (2.5 inches) rigid conduit is required to be installed from the meter mounting device to the supply trench to accommodate Manitoba Hydro's supply conductors.

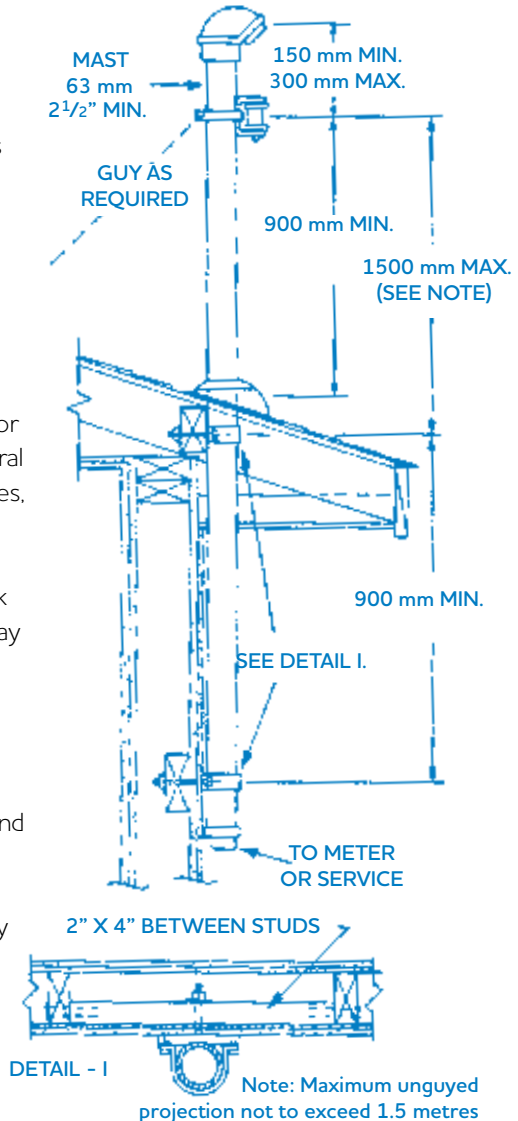

Minimum clearance requirements - Figure 7

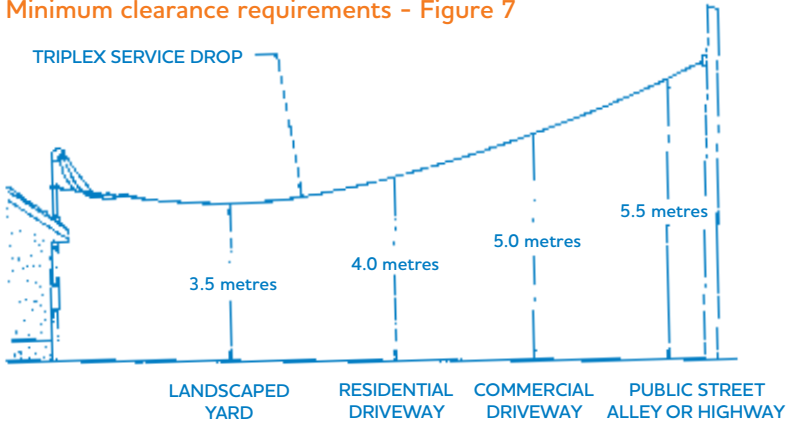

Figure 8

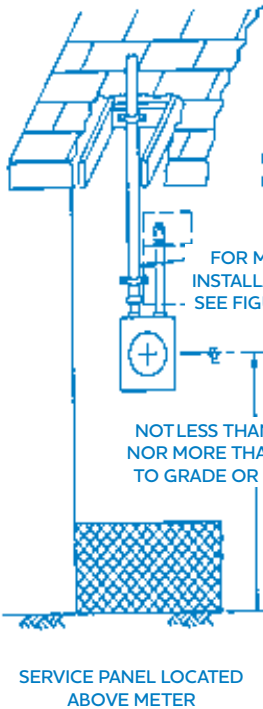
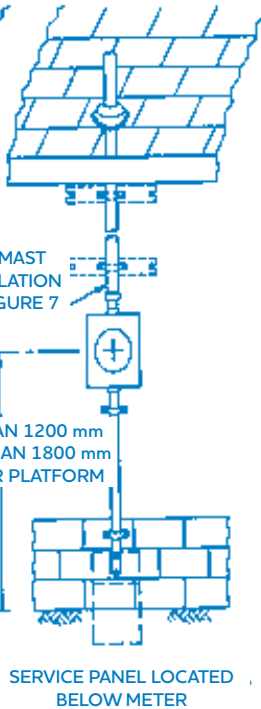

Figure 9



3/4" PLYWOOD



Backboard installation and panelboard mounting heights - Figure 10

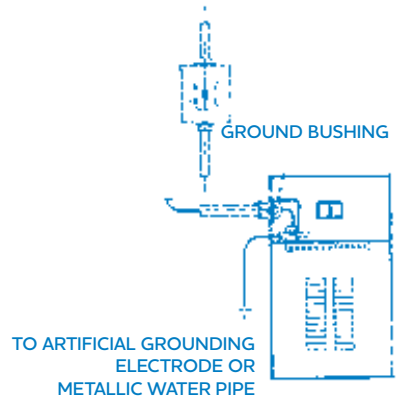

Backboard installation and panelboard mounting heights - Figure 11

## Service box and distribution panel

The service box and distribution panel contain the main disconnect and fuse or main circuit breaker, the fuses or circuit breakers which protect each individual circuit in the building, and the grounding connection for the system. They make up the main electrical control centre for home or cottage wiring.

The service conductors from the load side of the meter socket are connected to the line side terminals inside the service box.

The distribution panel may be part of the main service box or may be a separate panel. However, when the distribution panel and the main service box are combined, it is called a combination panel.

Examples of circuits and their uses are:

- **120 volts** – lights and convenience outlets.
- **120/240 volts** – range and dryer, etc.
- **240 volts** – baseboard heaters, electric water heaters, and central air conditioners which are rated at 240 volts.

The service box and distribution panel are located on the inside of the building. However, they must not be located in closets, bathrooms, or other similar undesirable places. The distribution panel must be located as high as possible above the finished floor, with no overcurrent device operating handle in the distribution section being more than 1.7 metres above the finished floor. It is recommended that a 3/4 inch thick piece of plywood of sufficient size to extend beyond the panel be used (see Figure 10) for mounting the panel.

## Service grounding

All service entrance metal parts, including conduit, meter fittings, and boxes must be grounded in accordance with the Manitoba Electrical Code. Figure 11 illustrates one method of connecting the grounding conductor in a service entrance.

The grounding conductor connects the neutral bus bar in the service box to the grounding electrode.

The grounding electrode may be a metallic public water system, in which case you would connect the grounding conductor to the street side of the water meter. When there is no public water system, e.g., at a cottage location, you must use an artificial grounding electrode, such as two approved copper-clad ground rods (at least 3 metres x 15.8 mm) spaced 3 metres apart. If you're unable to drive the ground rod into the earth below ground level near the structure, select an area where the ground rod can be driven easily. The bare grounding conductor must be connected to the ground rod by an approved clamp. The top of the rod should be below grade.

An alternative artificial grounding electrode is a ground plate or plate electrode. A plate electrode must have a surface area of not less than 0.2 square metres, not less than 6 mm thick if made from iron or steel, and not less than 1.5 mm thick if made from non-ferrous metal. It must also be buried at least 600 mm below finished grade.

## CHAPTER V – CIRCUITS

The two bus bars in the distribution centre allow you to divide the current into smaller units for feeding the branch circuits, using a circuit breaker or a fuse for each circuit.

A 120 volt circuit consists of one live conductor and one neutral conductor. Each 120/240 volt circuit consists of two live conductors and one neutral conductor. Each 240 volt circuit consists of two live conductors.

### Running cables

When wiring the circuits of a home or cottage, you will run type NM cable through the studs and joists. Where the cable is run between boxes and fittings, it shall be supported by straps or other devices. Cables run through holes in joists or studs shall be considered supported. Cables shall not be run on or across:

### Typical branch circuit wiring Figure 12

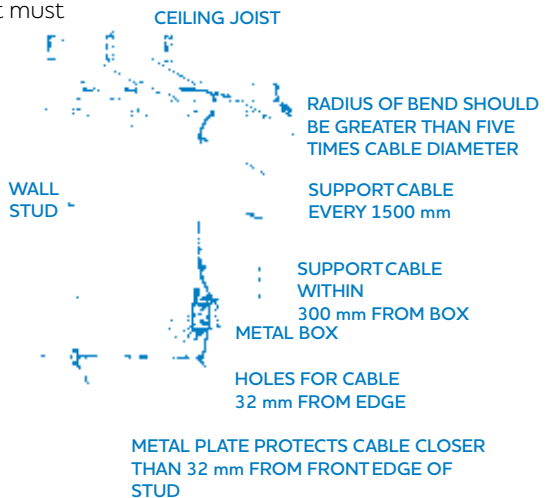

- a) the upper faces of ceiling joists or the lower faces of rafters in attic or roof spaces, where the vertical distance between the joists and the rafters exceeds one metre, or
- b) the lower faces of basement joists, unless suitably protected from mechanical injury.

Cables may be run across the upper sides of ceiling rafters where the vertical distance between the joists and rafter is less than one metre.

Drill the correct size of hole for the size of cable being used. Holes should be large enough so that the cable is not pinched, but not so large as to weaken the member. If the cable is run less than 32 mm from the face of the stud, you must install a metal plate (16 gauge) on the face of the stud so that the cable is protected.

Cable must be supported every 1500 mm as well as within 300 mm of the boxes as illustrated in Figure 12. The cable must be secured to the box. This can be accomplished in several ways: using boxes with built-in cable clamps (see Figure 14) or by using cable connectors (see Figure 15). Distribution panels are not equipped with built-in cable clamps, so cable connectors must be used.

Remove the outer jacket of the cable. 150 mm of conductor must be left in the box to attach to the device being installed.

Outlet box supports  
Figure 13

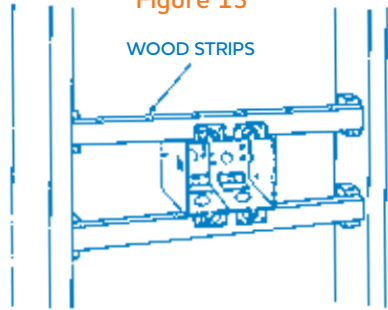

Outlet box with built-in cable clamps - Figure 14

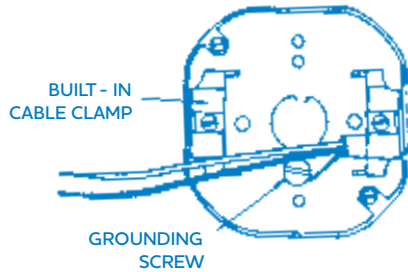

Outlet box supports  
Figure 15

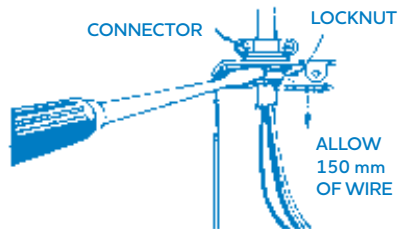

REMOVE LOCKNUT, PULL CABLE THROUGH CONNECTOR, TIGHTEN SCREWS, PUSH CONNECTOR THROUGH KNOCKOUT, SLIDE ON LOCKNUT AND TIGHTEN WITH A SCREWDRIVER

## Mounting boxes

Boxes must be properly supported as shown in Figure 12. Single boxes that will be used for duplex receptacles or switches are generally fastened to the studs, using wood screws.

However, when ganged sectional boxes are used, you will have to provide additional support with cross members which are fastened between the studs (see Figure 13). The support may consist of a board, which is wide enough to cover the entire back of the box, two wooden strips, or manufactured box supports which are obtainable from your electrical supplier.

When boxes having any dimension greater than 100 mm are used, they must also be secured on at least two sides e.g., dryer and range outlets and 3 gang one-piece boxes.

The Manitoba Electrical Code requires that the vapour barrier be maintained around boxes which are installed on outside walls and insulated ceilings.

## Receptacles

Receptacles have three different coloured screw terminals:

- Brass - coloured screws for live conductors
- White or silver - coloured screw for neutral conductors
- Green - coloured screws for the circuit bonding conductor (see Figure 16).

When you connect a duplex receptacle, connect the live conductor (black or red) to one of the brass - coloured screws. Since the brass - coloured screws are connected to a conductive tab on duplex receptacles, there's no need to connect both terminals. The same applies for the white or silver - coloured screws for the neutral conductor. Only one white or silver - coloured screw is necessary to connect the white neutral conductor.

Identification of terminal screws on receptacles  
Figure 16

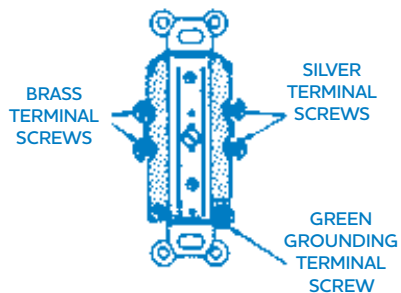



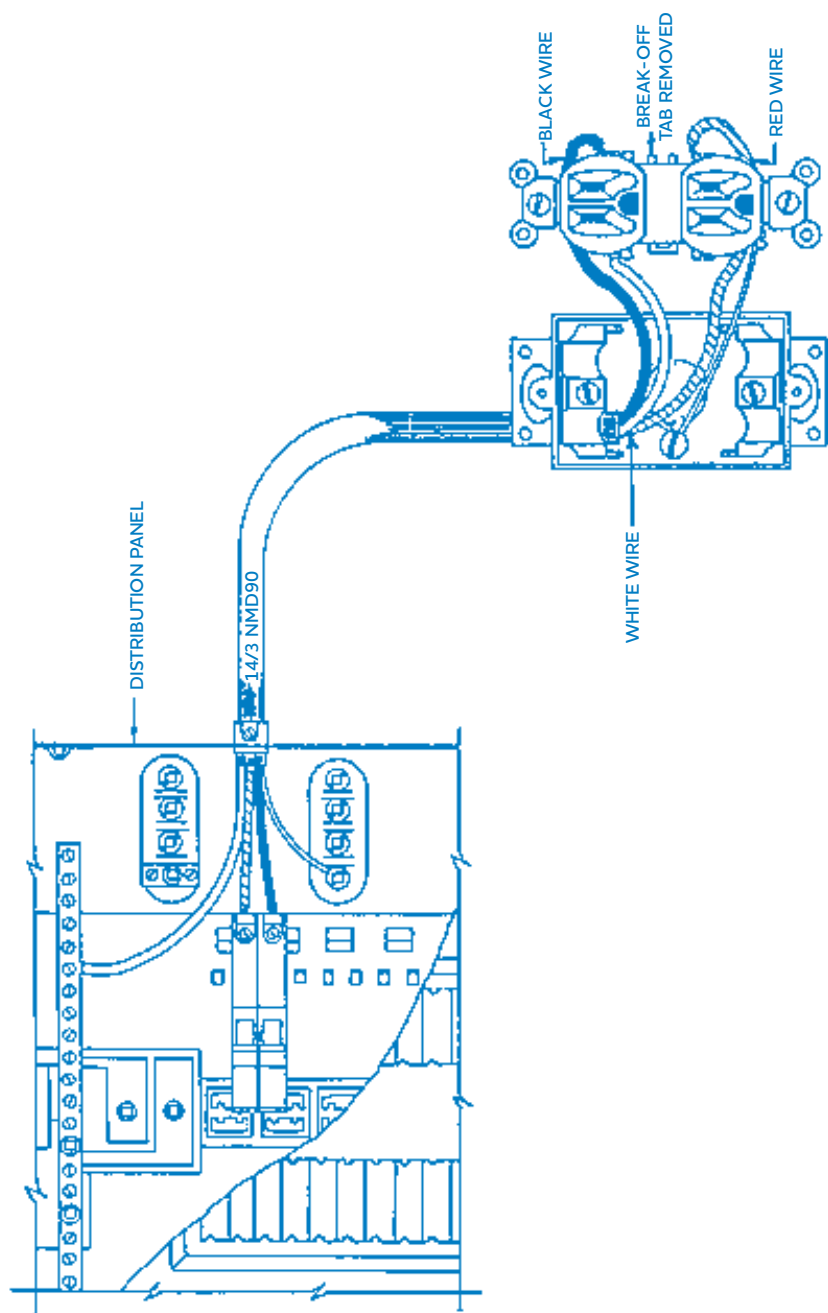

Split receptacle installation - Figure 17

Switch-loop colour coding - Figure 18

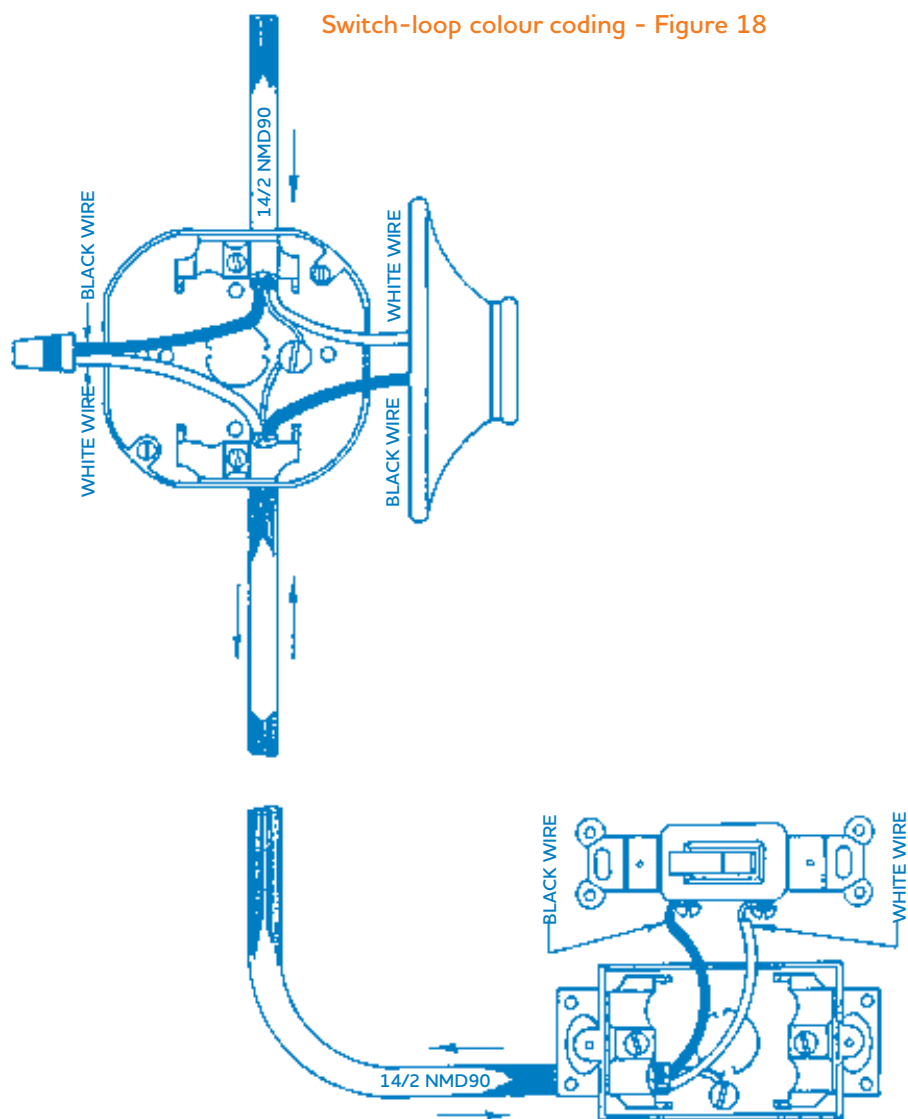

In some instances, you'll have to connect split receptacles. To do this, use three-conductor NM type cables instead of two-conductor. Use a duplex receptacle for the split receptacle, but on the side where the live conductors are connected, remove the break-off tab. Then connect the black conductor to one of the brass-coloured terminals and the red conductor to the other brass-coloured terminal. Connect the white conductor to the silver-coloured screw (see Figure 17).

Remember that both the metal box and the receptacle must be bonded. To do this, loop the bare bonding conductor under one of the two bonding screws in the box, and then connect it to the green-coloured screw on the receptacle (see Figure 19).

### Colour coding of conductors

Usually, conductors that are black, red, or any colour other than white or green are considered live. White denotes the neutral conductor and green denotes the bonding conductor. However, there are two exceptions to this rule:

- When a switch loop (as shown in Figure 18) is installed using two-conductor cable, one black conductor and one white conductor, the white conductor is used as the feed wire going to the switch, and the black conductor must be used as the switch return.
- When feeding 240 volt equipment, such as electric baseboard heaters or water heaters, the white conductor may be used as a live conductor, provided it is marked by painting or taping.

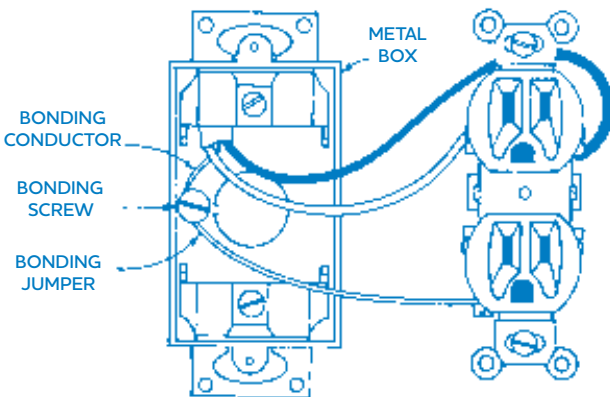

Receptacle bonding conductor connections  
Figure 19

## CHAPTER VI – WIRING TIPS

### Attaching conductors to screw type terminals

Strip 13 mm to 19 mm of insulation from the wire. Then, using needle nose pliers, form a three-quarter loop in the uncovered conductor. Hook the conductor clockwise around the screw so that as you tighten the screw, the loop of wire will close and form a tight connection. Make sure the insulation on the conductor does not extend under the screw as this will make a poor connection.

### Use of wire connectors

The most common method of connecting conductors is to use a wire connector. The recommended practice for making this connection is as follows:

1. Remove the insulation to expose the ends of the conductor in accordance with the manufacturer's instructions.
2. Hold stripped ends together, with ends of the wire even.
3. Push connector firmly against the wire ends and twist on the connector.

### Supporting cables

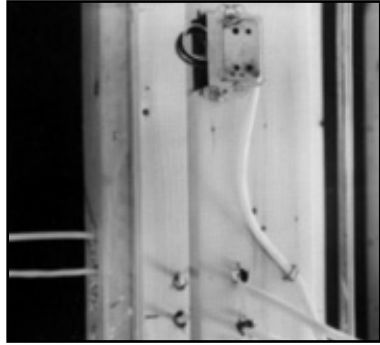

*When running cables through joists and studs, be sure to drill the holes large enough so the cables are not pinched or crushed.*

### Metal protectors

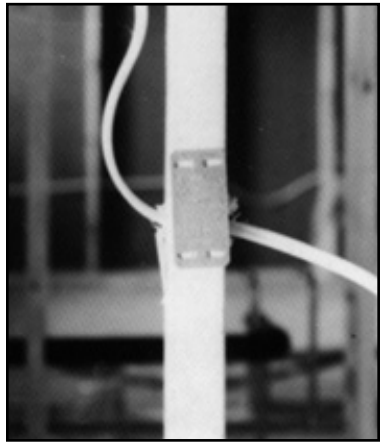

*Use metal plates in situations where the cable is too close to the front of the studs or joists.*

## CHAPTER VII – INSPECTIONS

When your work is completed at certain stages, the wiring will need to be inspected by the electrical inspector. Permit fees normally cover both the rough-in/service inspection and final inspection. The rough-in and service are intended to be inspected at the same time. If power is required to operate power tools during the construction, as outlined in Chapter IV, an extra service inspection will be required at an additional fee.

### Rough-in/service inspection

This inspection is made before the wiring is covered by insulation, a vapour barrier, or wallboard.

Before calling an electrical inspector for the rough-in/service inspection, the following work must be completed:

- The wiring for lights, switches and receptacles must be installed in the walls, secured to the structural members, and terminated in the outlet boxes.
- All the connections, joints and grounding in the outlet boxes must be completed. Only the conductors required for the connection of the light fixtures, receptacles or switches should be left unconnected.
- The service wiring and grounding must be completed

### Final inspection

The electrical installation must be complete. The light fixtures, receptacles and switches must be installed and connected. The electrical circuits in the panel must be clearly identified as well. Finally, the cover plates for receptacles and switches must be installed.

### Service inspection

If a service inspection is required to facilitate the construction and wiring of the structure, it will be carried out when the service is installed in its permanent position and one convenience outlet is connected.

If a temporary service is required, as outlined in Chapter IV, or extra inspections to facilitate construction schedules are necessary, then additional inspection fees will apply.

## CHAPTER VIII – WIRING AN EXISTING BUILDING

Whether you plan to build an addition, add a room to a home or cottage, or finish a recreational room, the same basic principles of wiring and guidelines apply. You must obtain an electrical permit and the installation must meet the requirements of the current Manitoba Electrical Code.

### Service size

Make sure your existing service will be large enough to handle the additional load. If you are uncertain, check with your electrical inspector to see if the existing service is adequate.

In order to accommodate additional circuits, you may have to install a larger panel or an additional panel. The new panel must be installed according to the latest Code requirements regarding location, ampacity, and the number of circuit positions.

### Upgrading existing branch circuits

When you plan to connect new wiring to existing branch circuits, remember that both the old and new wiring must comply with the latest Code standards.

For instance, if the existing cable is damaged, it must be replaced with new cable.

If there are extension cords in your home that are used on a permanent basis to connect a freezer, washing machine, lamp, or a television set, you must install additional electrical outlets. It is hazardous to use extension cords as permanent wiring.

Appliances such as a freezer or washing machine should be on separate circuits. An outlet for a television set and similar equipment may be connected to an existing circuit, as long as it will not overload that circuit.

Make sure that all the cables are properly supported and that any broken switch face plates or outlet face plates are replaced. Receptacles in the kitchen, bathroom, and laundry room must also be properly bonded.

## Safety

The Manitoba Electrical Code exists to ensure the safe installation and operation of wiring systems. The Code applies to both new and existing structures.

Keep these safety rules in mind when you work on existing wiring:

- Ensure that cables and equipment are de-energized before you start any work. You must either turn off the circuit breaker for the circuit you're working on; remove the fuse for the circuit; or turn off the main switch. Never work with live conductors.
- Before you begin to work on a circuit, test to insure it has been turned off.
- If you have to increase the service size, have Manitoba Hydro disconnect the service at the entrance. Do not disconnect the service yourself, and never make the changeover while the lines are energized.
- Do not proceed until you know how to complete the job properly and safely.

